

DC REMOTE OWNERS MANUAL

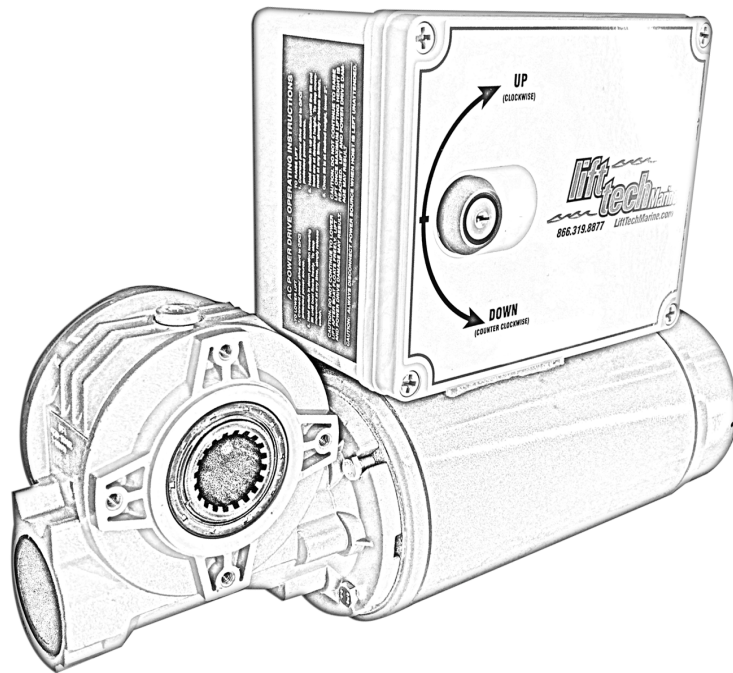

WWW.LIFTTECHMARINE.COM

Operating the DC Motor:

When the lift is going “up” the gear head should be going clockwise. When the lift is going “down” the gear head should be going counterclockwise. If it is going the opposite direction this means your lift was let down too far and now your lift is backwound. To fix this, let the lift down, when it runs out of cable it will wind itself up correctly and start going up.

Remote Controls:

If the remote controls stopped working but your key still works, simply unplug the motor from the battery. After one-minute plug the motor back into the battery and the remote controls should work. If they do it means the remotes were put into a safety mode because your batteries are over charge. Along with the two remote controls that came with your motor you can also download the phone app and control your motor with your phone. See the included Bluetooth instructions.

Off-Season Storage:

We recommend our storage cover for your motor if you are going to leave it sit outside during the winter months. Our storage cover will breathe and let moisture out while your not using your motor. If you decide to cover the motor with a bag instead, make sure not to seal it completely or condensation can develop and the warranty will be void.

Power Outage:

In case of a power outage, use the provided back up bit (inside white floatie) on the end of the shaft with your drill. Visit our website to watch a video on how to use the back up bit.

Power Requirements:

Our DC Motors can be 12 volts or 24 volts.

If running 24 volts make sure to hook your batteries up in a series. (See image on right)

We recommend 24 or 27 series deep cycle batteries.

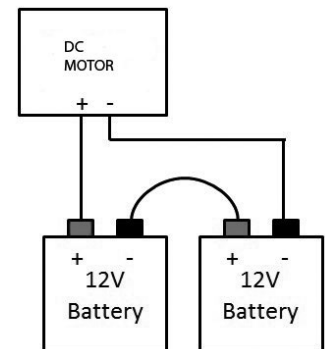

Maintenance:

Our motors are self-lubricating and do not need any maintenance.

Solar Panels will evaporate water so make sure to check water levels in the battery to prevent battery damage and possible battery explosion. We recommend all solar panels use a charge control to prevent over charging. They can be purchased separate.

Website:

Go to www.lifftechmarine.com for more information, troubleshooting and how to videos.

We would like to take this opportunity to say thank you. We value you as a customer. Should you ever have an issue please give us a call at 866-319-8877 or send us an email at customerservice@lifftechmarine.com

PLASTIC COVER



OPTIONAL STORAGE COVER



CANOPY LIGHTS

